

LOC	DIST	REVISIONS					
AF	50	P	LTR	DESCRIPTION	DATE	DWN	APVD
			T3	REV PER ECR 07-015235	27JUL07	JR	PD

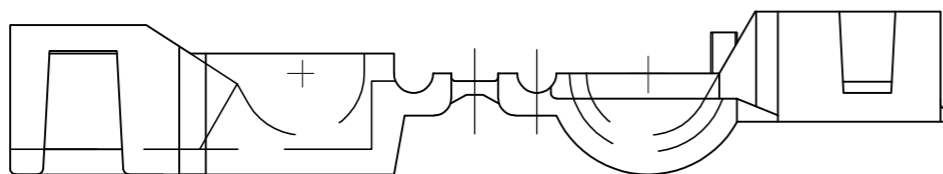
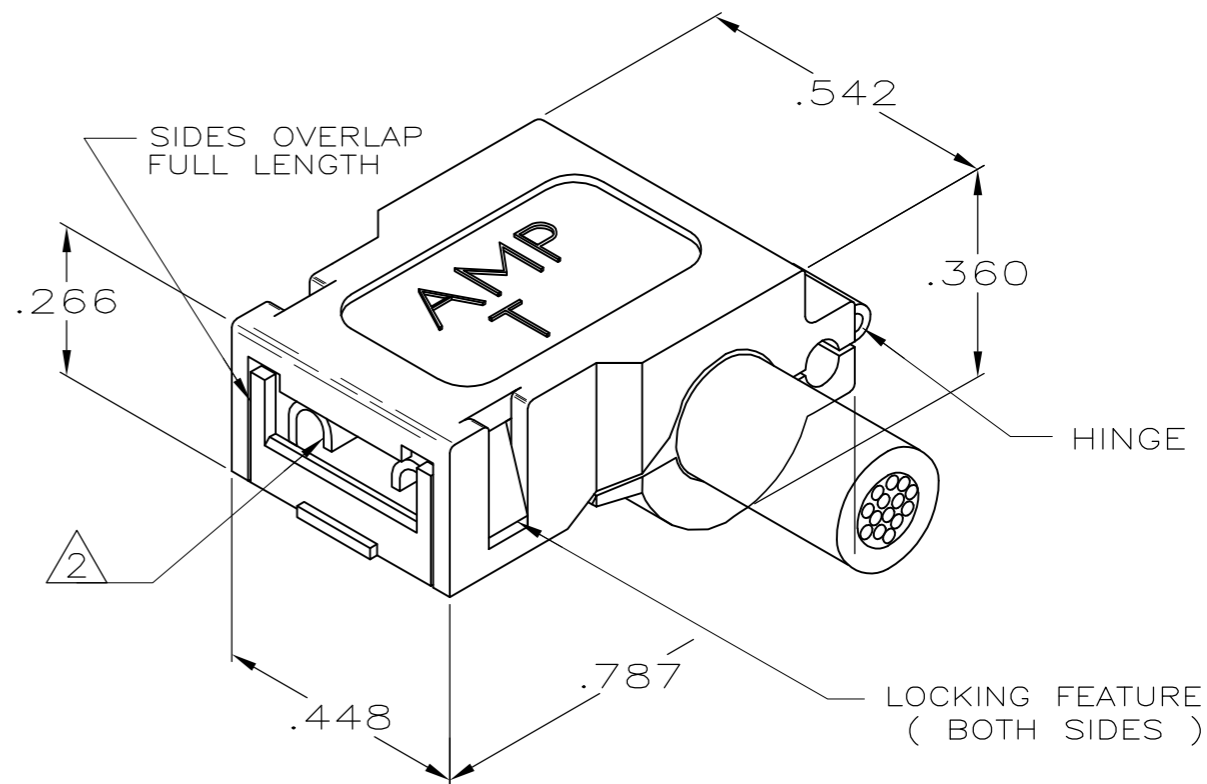
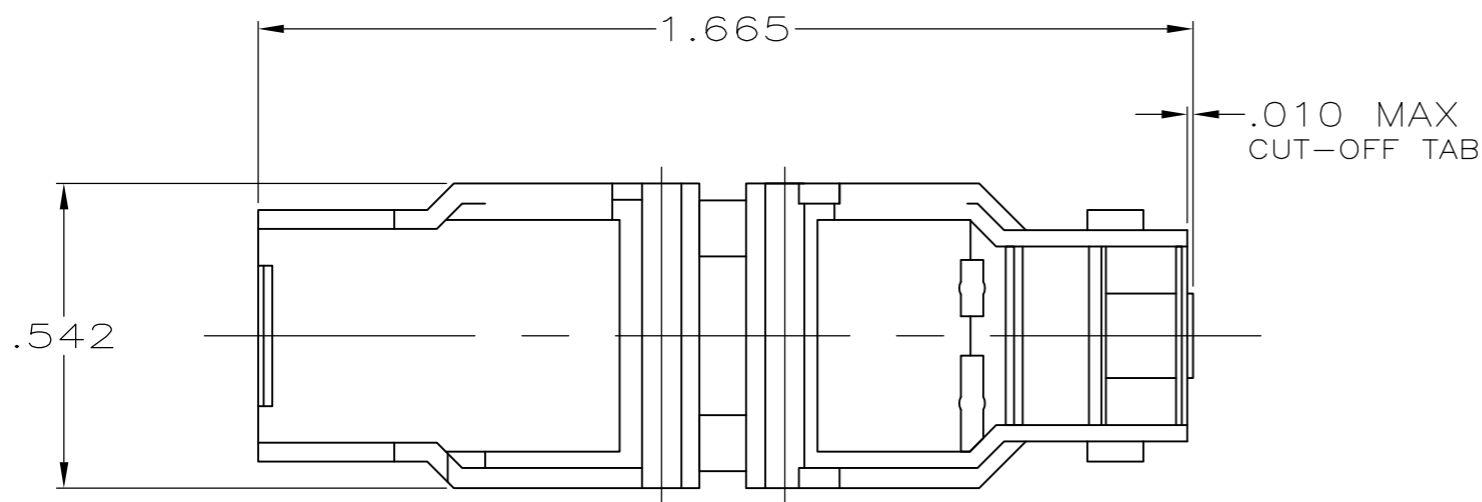
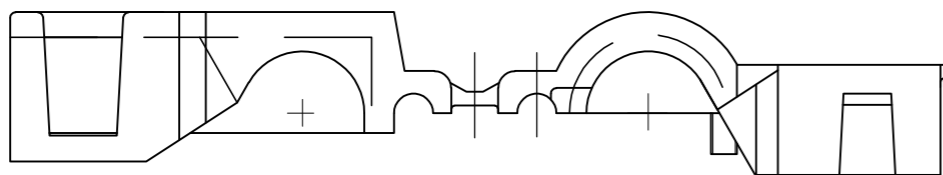

- 1 SUPPLIED IN LOOSE PIECE.
- 2 THIS PART ACCEPTS .250 SERIES FASTON FLAG RECEPTACLES PART NUMBERS 41531, 41532, 42511, 60641 AND 60645.
- 3 SEE CP-23587 FOR RECOMMENDED TAB DETAILS.
- 4 MAX INSULATION IS .210.

5 GLOW WIRE APPROVED, CONTACT TYCO ELECTRONICS FOR ENGN SPECIFICATIONS, ALL WALL THICKNESSES ARE BETWEEN 0.4mm AND 3.0mm.

-	5	1-480307-8
120° C	VO, 6/6 NYLON - NATURAL	1-480307-7
150° C	4/6 NYLON - NATURAL	1-480307-6
125° C	6/6 NYLON - NATURAL	1-480307-1
UL TEMP RATING	MATERIAL/COLOR	PART NO.

THIS DRAWING IS A CONTROLLED DOCUMENT.		DWN	JR RUTH	1/24/97	Tyco Electronics Corporation Harrisburg, PA 17105-3608											
DIMENSIONS: INCHES		CHK	MS FEHER	1/24/97												
TOLERANCES UNLESS OTHERWISE SPECIFIED:		APVD	R BEAVER	1/24/97	NAME											
0 PLC ± - 1 PLC ± - 2 PLC ± - 3 PLC ± .015 4 PLC ± - ANGLES ± -		PRODUCT SPEC		INSULATION POD, AMPIP-POST												
MATERIAL		APPLICATION SPEC		RESTRICTED TO												
SEE TABLE		FINISH		SEE TABLE												
		WEIGHT	-		SIZE	A3	CAGE CODE	00779	DRAWING NO	C-480307	SCALE	4:1	SHEET	1 OF 1	REV	T3
CUSTOMER DRAWING																